

LPA Concepts

LINEAR POWER AMPLIFIER	LPA-AH0C-040AB-3300M-3800M-48-00
P2970	
FEATURES <ul style="list-style-type: none"> ◆ 3300-3800MHz ◆ Gain : 36 dB ◆ 40W P_{-2dB}, Class AB ◆ CW or pulse operation ◆ +48V / 2.3 A @ 40W CW ◆ Protection against reverse voltage, over current and over temperature ◆ Fast On/Off switching ◆ RoHS compliant 	<p style="text-align: center;">AH0C PACKAGE</p> 
	<p style="text-align: center;">APPLICATIONS</p> <ul style="list-style-type: none"> ◆ Instrumentation

BLOCK DIAGRAM

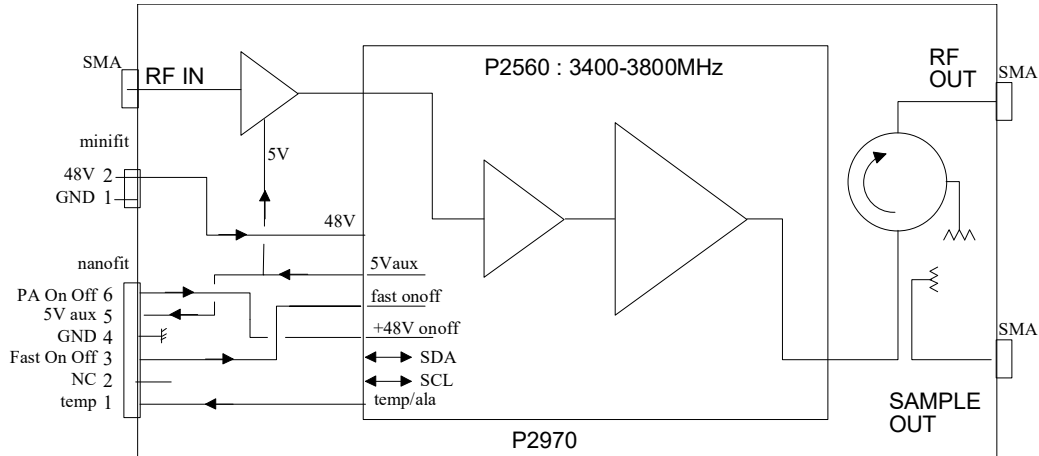

Specifications and information are subject to change without notice

LPA Concepts

Electrical characteristics: 50 ohms; +48V; -25°C to +80°C (1)

Ref	parameter	conditions	note	min	typ	max	units
1	Bandwidth			3300		3800	MHz
3	Small signal Gain	3600 MHz; 50°C		34	36		dB
	Ss Gain variation vs temp	-25°C to +80°C	2		5		dB
4	Gain at 40W	3600 MHz; 50°C		32	34		dB
5	Gain variation vs frequency	3400 MHz - 3800 MHz				2	dBpp
6	Sample output	Relative to main output			-30		dBc
7	Input return loss	50 ohms				-15	dB
8	Output return loss	50 ohms				-15	dB
9	Multi tones intermodulation	10 tones 1MHz spacing, 40W peak,	3		-27	-25	dBc
10	Peak envelope power	2 tones , IMD3 = -27 dBc			50		W
11	Current consumption	48V, idle			0.25		A
12	Current Consumption	48V, 40W CW 3600MHz			2.3		A
13	Fast on/off control	TX ON			0	0.3	V
14	Fast on/off control	TX OFF		2.5	3		V
15	signal rise time	3V to 0V negative edge	4			1	μs
16	Rise time delay		4			3	μs
17	Signal fall time	0V to 3V positive edge	4			1	μs
18	Fall time delay		4			3	μs
19	Gain TX OFF	Tx=3V			-50		dB

1. Unless otherwise specified
2. Hot Spot Temperature
3. Peaked phases
4. Low impedance drive

Maximum ratings

Ref	parameter	conditions	note	min	Nom	max	units
1	Operating temperature	Flange temperature		-40		+90	°C
2	Supply voltage			30	48	50	V
3	Input power	CW				+6	dBm
4	Reverse power					46	dBm
5	Max load VSWR	@ 40W output				∞:1	-

Protections

Ref	parameter	description	remarks
1	Overvoltage	Shut down if supply > 50 V	
2	Under voltage	Shut down if supply < 30 V	
3	Reverse voltage	No current drawn	
4	Overcurrent	Shut down if current > 2.5 A	Lower power and PA On/Off to recover
5	Temperature	Shut down if temp > 80°C	Auto recover at 75°C

Monitoring & control

Ref	characteristic	description	remarks
1	PA On/Off	48V switching (used for reset)	+0V=ON internal pull down
2	Fast On/Off	Gain switching	+0V=ON internal pull down
3	Temperature	Analog output	-40°C to +100°C (TMP20)
4	Alarm		<0.1V for alarm

Specifications and information are subject to change without notice

LPA Concepts

Part numbering:

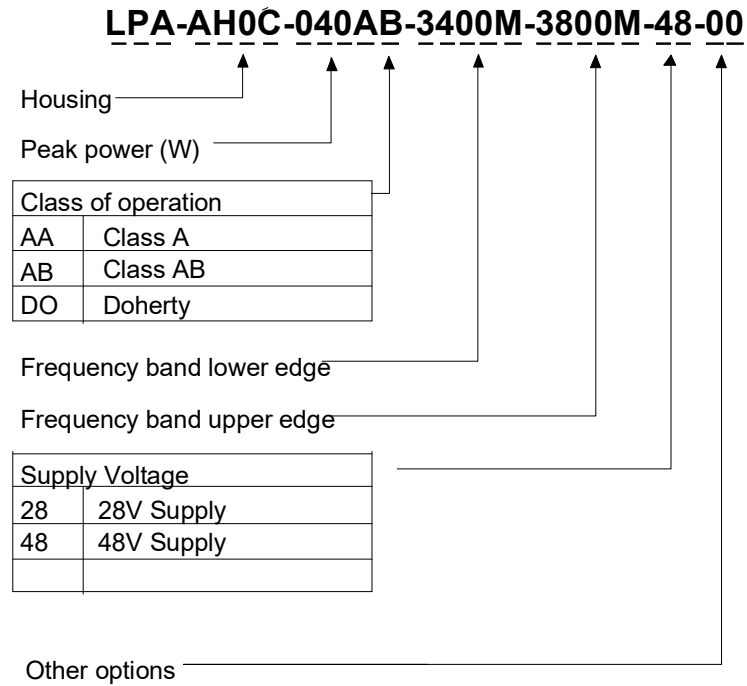

Support material

Ref	Characteristic	Description	Remarks
1	T280	Analog control board	uses 5V aux from amplifier
2	P3090	Analog control & ALC board	uses 5V aux from amplifier
3			

Related products

Ref	Characteristic	Description	Remarks
1			
2			
3			

Communication DC Connector Molex NanoFit 105405-1206

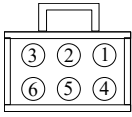
Pin description		Mate with 105308-1206	PINOUT 
Pin 1 : Analog temperature	Pin 4 : Gnd		
Pin 2 : NC	Pin 5 : 5V aux		
Pin 3 : Fast on/off	Pin 6 : Power On/Off		

Specifications and information are subject to change without notice

LPA Concepts

Power Supply DC Connector Molex MiniFit Jr 39-30-1020

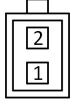
Pin description		PINOUT
Pin 2 : Supply +48V		
Pin 1 : Gnd		
	Mate with 39-01-2020 and inserts 39-00-0038	

Mechanical characteristics

Ref	characteristic	description	remarks
1	Housing dimensions	135mm x 64mm x 21mm	
2	Housing finish	Electroless nickel (-00 option)	Surtec 650 (-01 option)
3	Mounting	4 M4 screws	
4	Input/output RF connectors	SMA	
5	DC supply connector	Molex 39-30-1020	Male type
6	DC controls connector	Molex 105405-1206	Male type
7	Weight	400 grams	

Package outline:

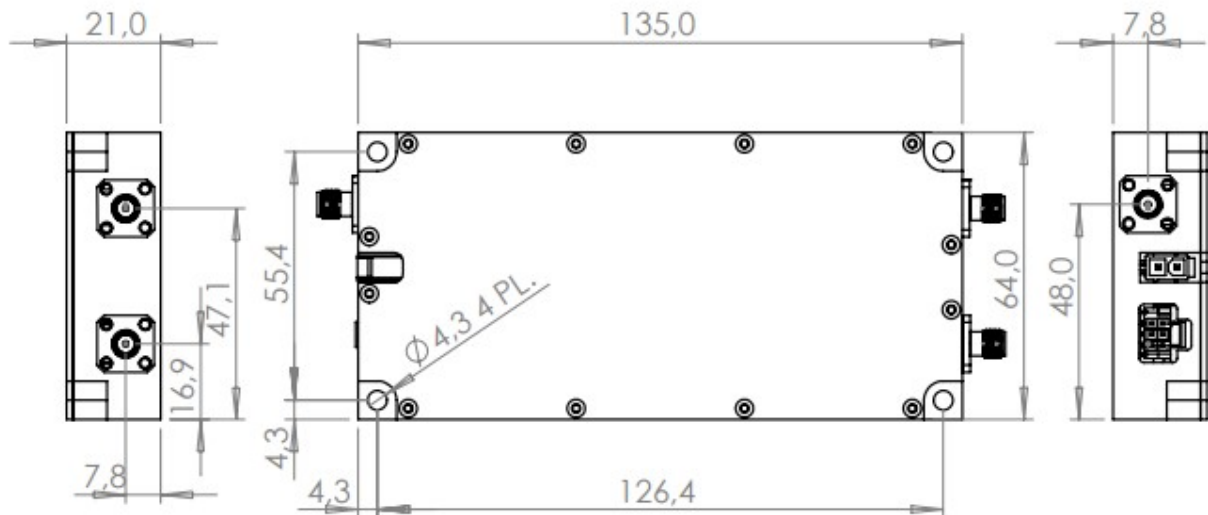

Specifications and information are subject to change without notice

LPA Concepts

TYPICAL PERFORMANCE

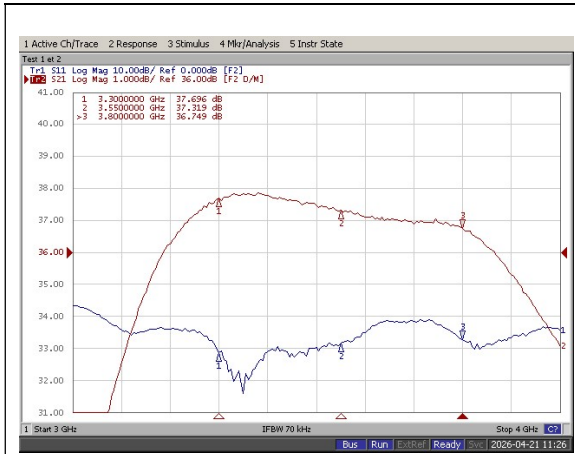

Gain vs frequency

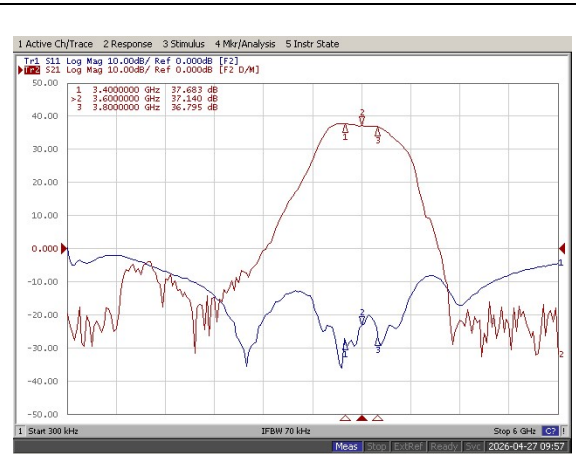

Wideband gain vs frequency

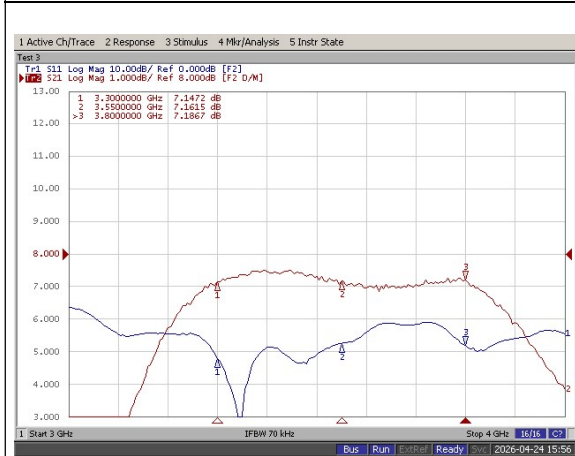

Sample

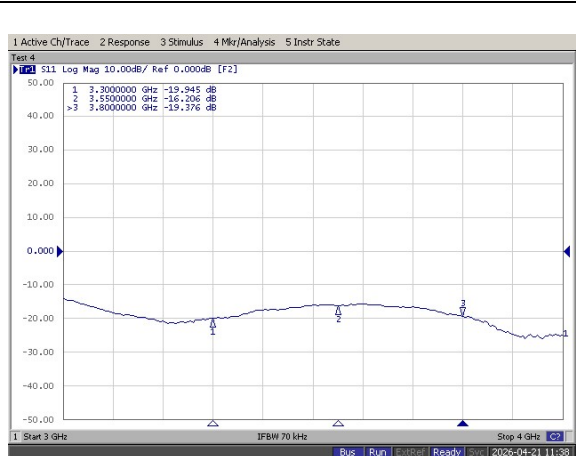

Output return loss vs frequency

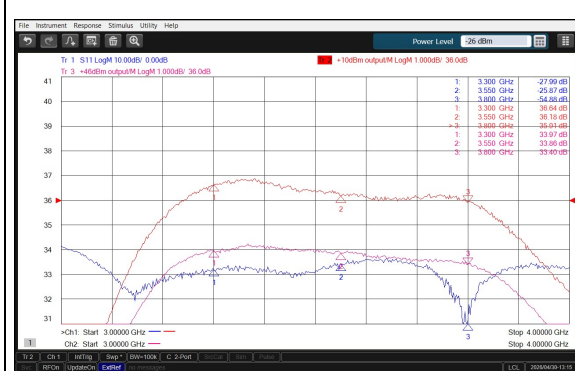

Gain compression @40Woutput (10μs/1ms pulses)

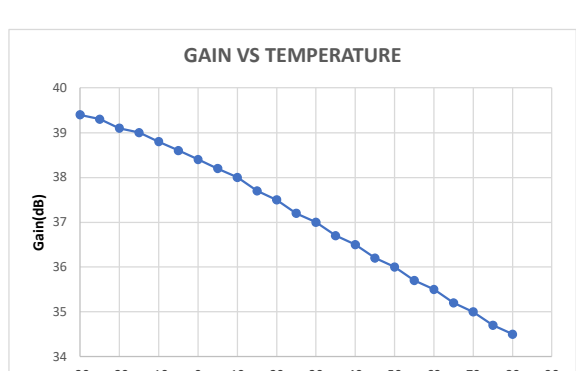

Specifications and information are subject to change without notice

TYPICAL PERFORMANCE (continued)

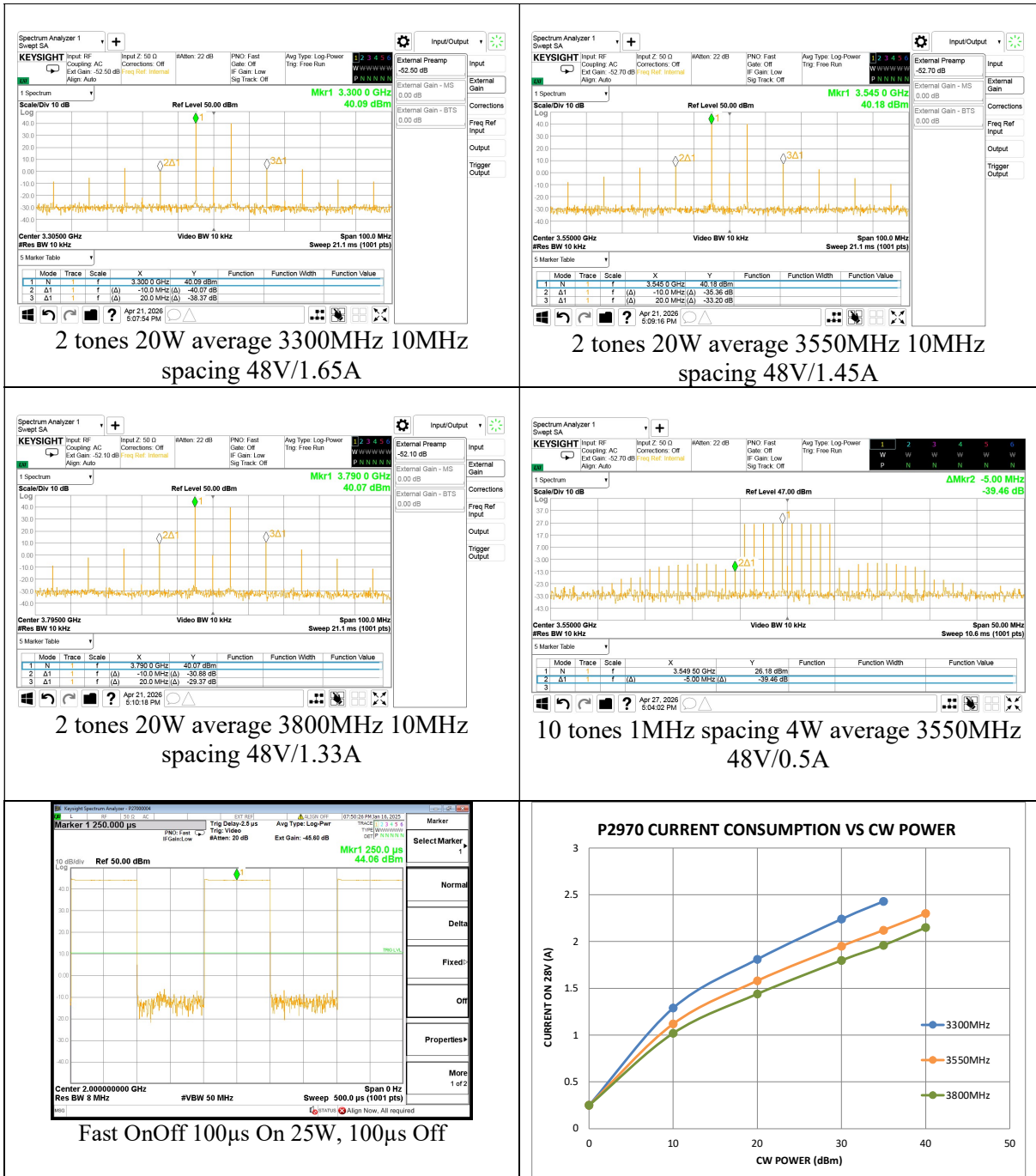

Specifications and information are subject to change without notice

LPA Concepts

TYPICAL PERFORMANCE (continued)

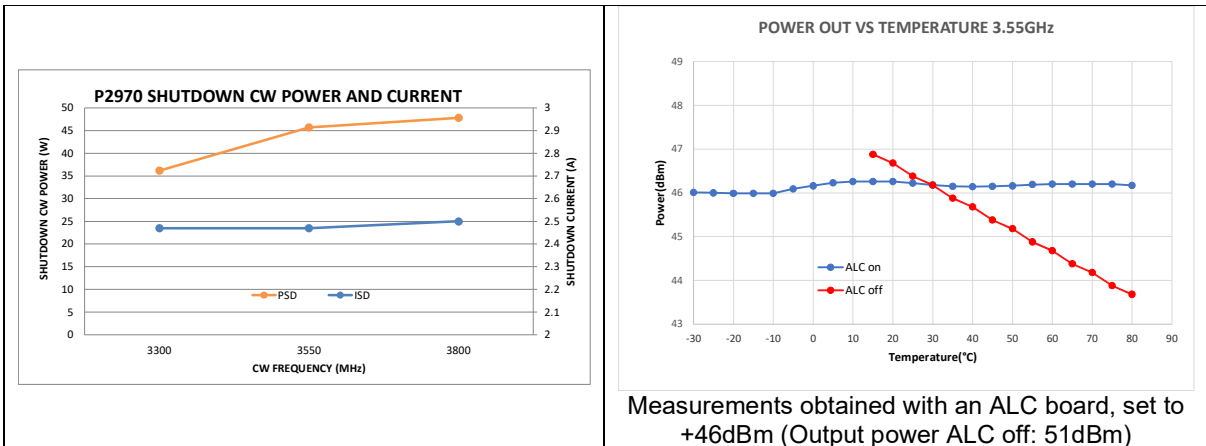

Specifications and information are subject to change without notice