

LPA Concepts

LINEAR POWER DRIVER AMPLIFIER	
P3210	LPA-LPD2-004AB-3800M-5000M-48-00
FEATURES <ul style="list-style-type: none"> ◆ 3800-5000MHz ◆ Gain: 28 dB / $P_{pep} = 4W$ ◆ 50Ω input / output ◆ 48V / 85mA idle ◆ 48V / 0.35A @ 4W CW ◆ Aluminum flange ◆ Low cost 	<p style="text-align: center;">PACKAGE</p> <div style="text-align: center;">  </div> <p style="text-align: center;">LPD2 package</p> <p style="text-align: center;">APPLICATIONS</p> <ul style="list-style-type: none"> ◆ General purpose

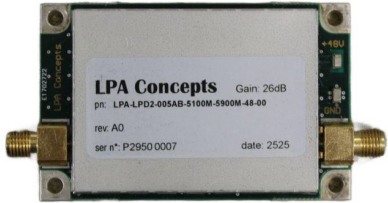
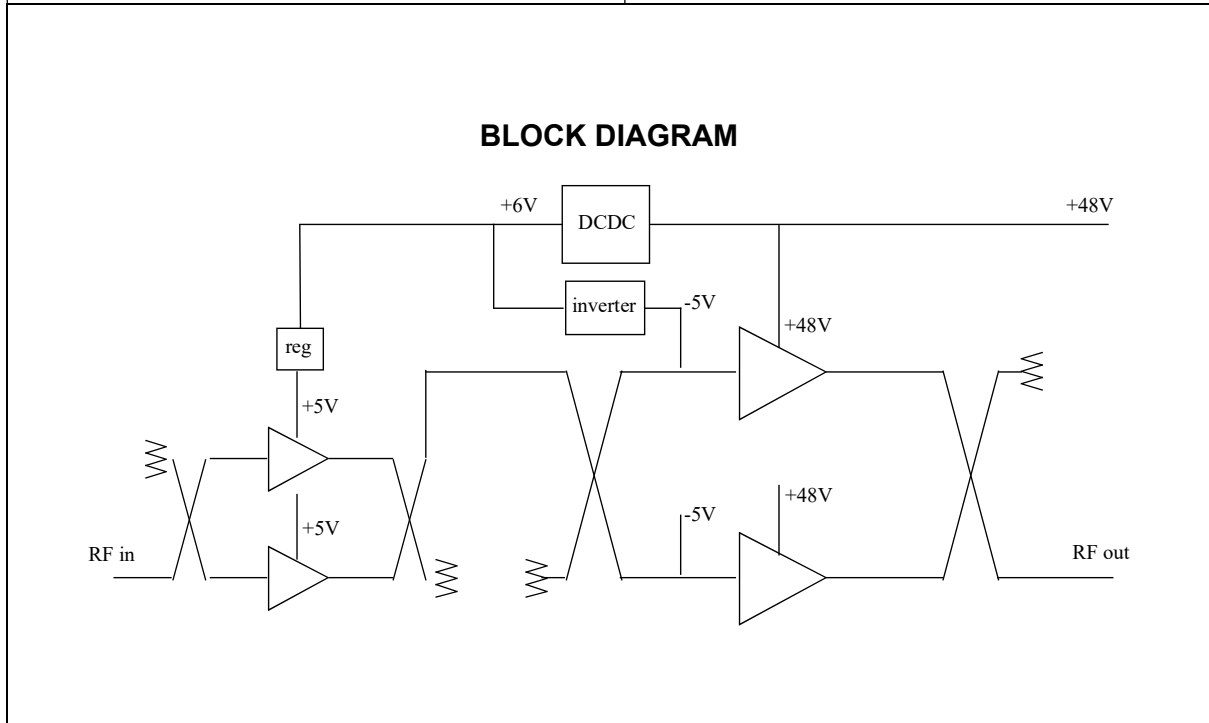

Specifications and information are subject to change without notice

LPA Concepts

Electrical characteristics: 50 ohms; +48V; -25°C to +80°C (1, 2)

Ref	Parameter	Conditions	Note	Min	Typ	Max	Units
1	Bandwidth			3800		5000	MHz
2	Gain small signal	4400 MHz; 50°C			28		dB
3	Gain variation vs frequency	3800 MHz - 5000 MHz			2	3	dBpp
4	Gain variation vs temperature	-25°C to +80°C	2		3		dB
5	Input return loss	50 ohms				-15	dB
6	Output return loss	50 ohms				-15	dB
7	Peak envelope power	IMD3 = -30 dBc, f=4400 MHz	3	4	5		W
8	Current consumption idle				0.08		A
9	Current consumption 4W	CW frequency 4400MHz			0.32		A
10	Max current	Shut down current			0.4		A

1. Unless otherwise specified
2. Housing temperature
3. 2 CW, tone spacing 5MHz

Maximum ratings

Ref	Parameter	Conditions	Note	Min	Nom	Max	Units
1	Operating temperature	flange temperature		-40°C		+80	°C
2	Supply voltage			46	48	50	V
3	Input peak power					+12	dBm
4	Input average power					+12	dBm
5	Max load VSWR	At 4W output			10:1		

Power Supply DC Connection

Pin description			
Terminal 2 : Supply +48V		SMD LOOP TERMINAL	3.3mm x 1.85mm x 2.0mm
Terminal 1 : Gnd			

Specifications and information are subject to change without notice

LPA Concepts

Mechanical characteristics

Ref	characteristic	description	remarks
1	Package dimensions	66mm x 42mm x 11mm	
2	Flange dimensions	66mm x 42mm x 5mm	4 x M3 screws for heatsink attach
3	Input/output RF connectors	SMA	
4	DC supply connection	SMD Loop terminal	For hook clip (Minigrabber or Micrograbber)
5	Weight	60 grams	

Package outline:

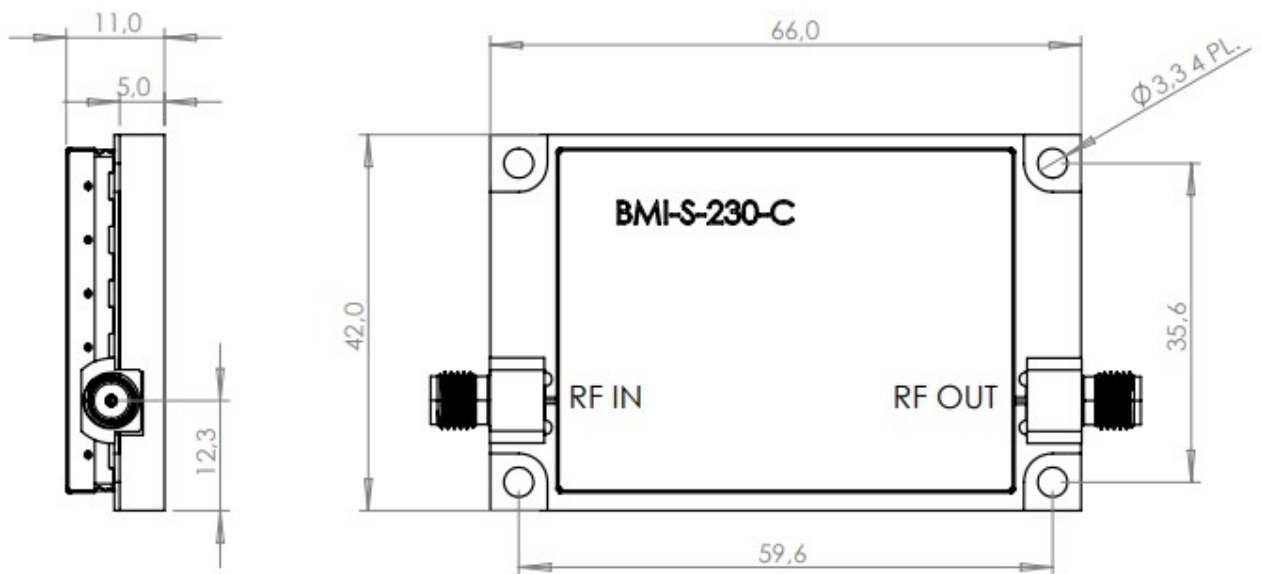

dimensions are in mm

Specifications and information are subject to change without notice

TYPICAL PERFORMANCE



Gain vs Frequency

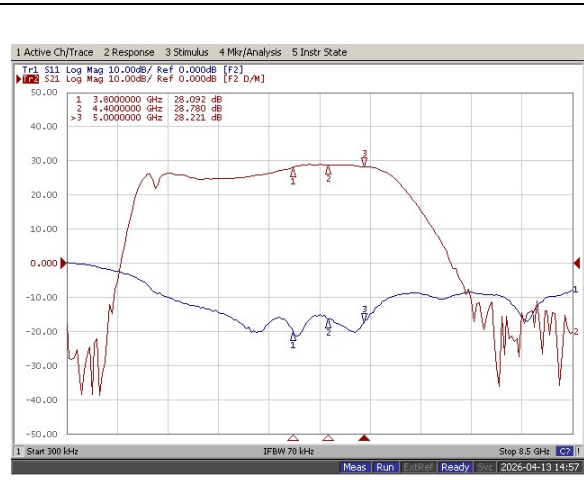

Wideband gain vs Frequency

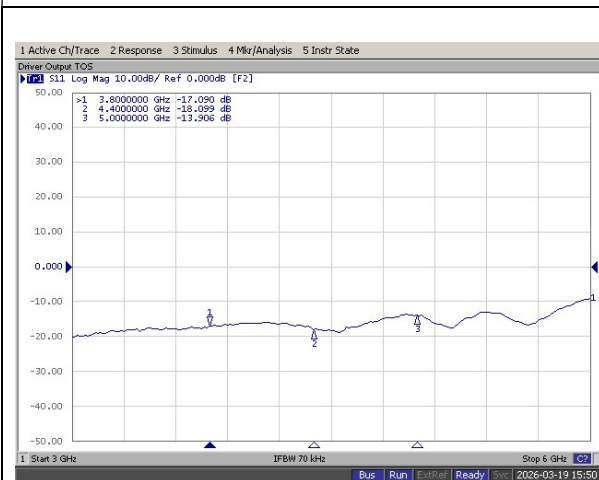

Output Return Loss vs Frequency



Gain compression at 4W

TYPICAL PERFORMANCE (continued)

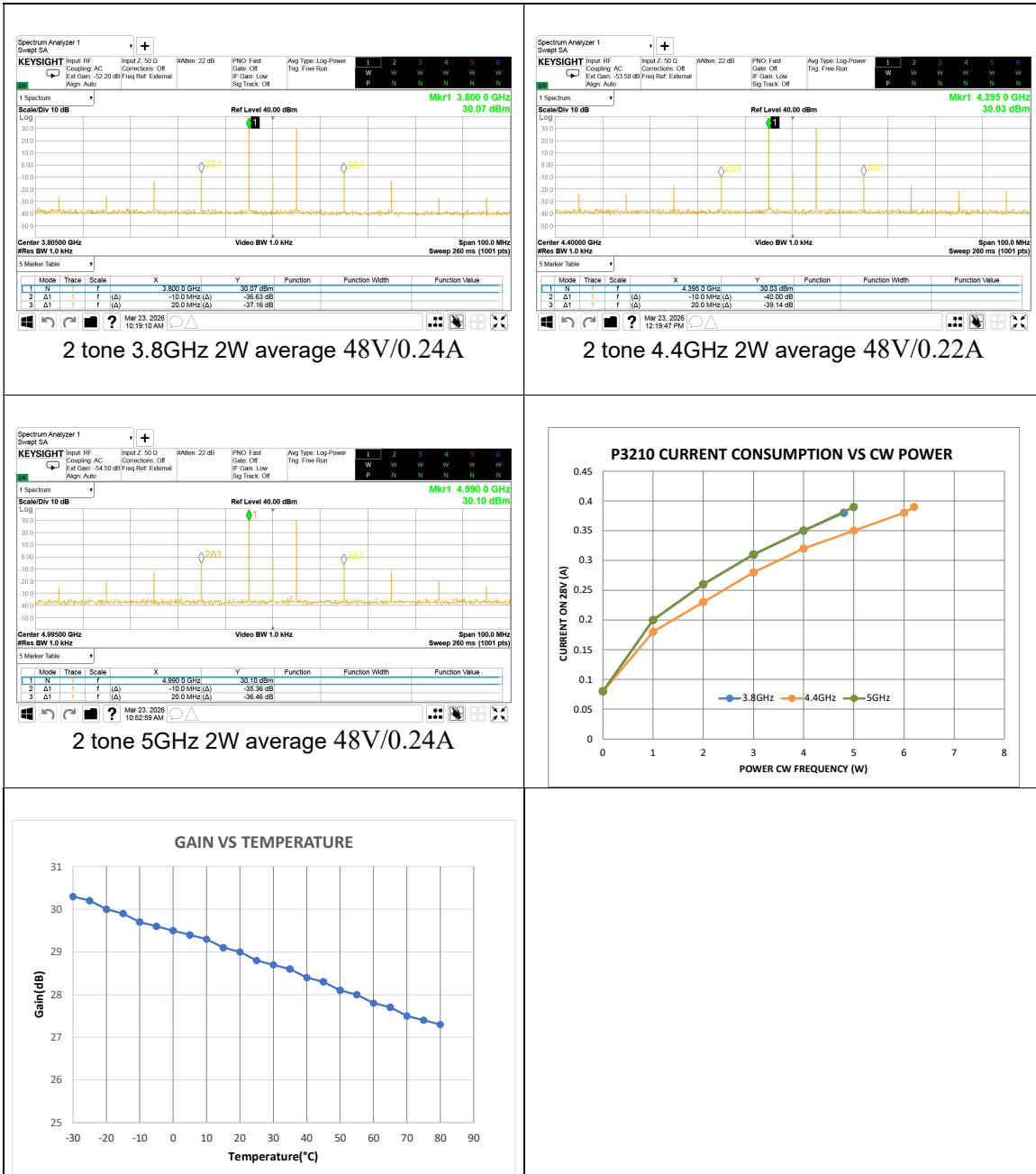

Specifications and information are subject to change without notice